

2NH_3 remained in the tube (identified by its X-ray powder pattern) along with a viscous liquid. Only a trace of $\text{H}_3\text{-NB}_3\text{H}_7$ could be sublimed from the reaction mixture.

4. **Small Scale Laboratory Synthesis Using Tetrahydropyran.**—A sample of tetraborane (1.69 mmole) was condensed into 2 ml. of tetrahydropyran and the system was warmed to room temperature. At room temperature the reaction was much slower than that with tetrahydrofuran. In order to minimize attack of the tetrahydropyran on the stopcock grease in the system, the temperature of the reactor was reduced to 0° and maintained for 15 hr. The B_2H_6 evolved (0.817 mmole) was separated by fractionation. The excess tetrahydropyran was removed at 0° ; 3 ml. of diethyl ether was condensed into the system; then a sample of ammonia (3.4 mmole) was added to the reactor and a temperature of -78° was maintained for 10 hr. On removal of the ethers a dry solid was left in the system. $\text{H}_3\text{-NB}_3\text{H}_7$ was sublimed at 52° to give an 81% yield (77.8 mg.).

In a second run using 4.75 mmole of B_4H_{10} and 1.5 ml. of tetrahydropyran conditions were the same as above except the system was allowed to stand for 24 hr. at -78° after addition of 9.80 mmole (2-fold excess) of ammonia. A 94% yield (0.253 g.) of $\text{H}_3\text{-NB}_3\text{H}_7$ could be sublimed from the solid residue.

The Reactions of $\text{H}_3\text{-NB}_3\text{H}_7$. 1. **The Reaction of $\text{H}_3\text{-NB}_3\text{H}_7$ with Sodium Dissolved in Liquid Ammonia.**—A sample of $\text{H}_3\text{-NB}_3\text{H}_7$ (0.189 mmole) was dissolved in about 1.5 ml. of liquid ammonia; sodium metal (0.1 g.) in a small glass tube was added in two portions by breaking the tube immediately before addition. After introducing the first

portion, the solution was warmed to -78° . The blue color of Na faded rapidly and 0.10 mmole of H_2 was evolved. No more H_2 was evolved at -78° over 12 hr. The second portion of Na then was added as above. In 20 minutes 0.012 mmole of H_2 was given off. After 5 hr. an additional 0.057 mmole appeared. Total $\text{H}_2 = 0.169$ mmole; $\text{H}_2/\text{H}_3\text{-NB}_3\text{H}_7 = 0.895$. Further gas evolution was very slow and the solution remained blue. The excess of Na was removed from solution by amalgamation at -35° . Additional H_2 (0.007 mmole) was given off during the amalgamation. The sodium-free clear solution was filtered from the amalgam, and the solvent ammonia was distilled from the filtrate. In the white solid residue NaBH_4 was detected by its X-ray powder pattern, but no component soluble in diethyl ether could be extracted from the residue.

2. **The Reaction of $\text{H}_3\text{-NB}_3\text{H}_7$ with Trimethylamine.**—A sample of $\text{H}_3\text{-NB}_3\text{H}_7$ (0.55 mmole) was placed in a tube and trimethylamine (0.565 mmole) was condensed above it. The system was allowed to warm slowly. At -78° no visible reaction was observed, but as the temperature rose and solid $\text{H}_3\text{-NB}_3\text{H}_7$ began to dissolve in liquid trimethylamine, fairly rapid reaction was noted. Without waiting for the completion of the reaction, the non-condensable gas and the volatile components were removed from the system. They were: $\text{H}_2 = 0.102$ mmole, $(\text{CH}_3)_3\text{N} = 0.24$ mmole and $(\text{CH}_3)_3\text{NBH}_3$ about 0.35 mmole. From the solid polymeric residue 0.20 mmole of $\text{H}_3\text{-NB}_3\text{H}_7$ was sublimed on warming to 40 to 50° . No $(\text{CH}_3)_3\text{NB}_3\text{H}_7$ could be detected as a product.

ANN ARBOR, MICHIGAN

[CONTRIBUTION FROM THE DEPARTMENT OF CHEMISTRY, UNIVERSITY OF MICHIGAN]

The Molecular and Crystal Structures of Ammonia-Triborane¹

BY C. E. NORDMAN AND CURT REIMANN²

RECEIVED DECEMBER 27, 1958

Ammonia-triborane, $\text{H}_3\text{-NB}_3\text{H}_7$, forms two crystalline modifications, a disordered, tetragonal form stable at about 25° , and an ordered, monoclinic form stable at lower temperature. Single crystal X-ray diffraction studies of both modifications show that the molecule contains a triangle of boron atoms with a non-coplanar NH_3 group attached to one corner. The arrangement of hydrogen atoms suggests that the B_3H_7 group is a rather strongly distorted fragment of the B_4H_{10} molecule, but the alternative description of $\text{H}_3\text{-NB}_3\text{H}_7$ as a bridge substituted diborane, $(\text{H}_3\text{-NBH}_2)_2\text{B}_2\text{H}_6$, cannot be entirely ruled out.

Introduction

Ammonia-triborane, $\text{H}_3\text{-NB}_3\text{H}_7$, was first prepared by Dr. G. Kodama³ of this Department. The synthesis was accomplished in low yield by allowing the recently described compound NaB_3H_8 ⁴ to react with NH_4Cl in the presence of diethyl ether.

The structure analysis of the high temperature, disordered modification, to be described below, was begun shortly after the chemical composition and molecular weight had been determined. The main objective of this phase of the structure determination was to establish the gross configuration of the boron-nitrogen skeleton of the molecule.

Ammonia-triborane has subsequently been obtained in good yield through the reaction of NH_3 with several etherates of B_3H_7 such as $\text{Et}_2\text{OB}_3\text{H}_7$,

tetrahydropyran- B_3H_7 , and others.^{5,6} These reactions proceed according to the equation $\text{NH}_3 + \text{R}_2\text{OB}_3\text{H}_7 \rightarrow \text{R}_2\text{O} + \text{H}_3\text{-NB}_3\text{H}_7$. It has been shown that such etherates of B_3H_7 are formed, along with B_2H_6 , when B_4H_{10} is allowed to react with the appropriate ether.⁶ The initial step in the latter reaction presumably involves a cleavage of the tetraborane molecule into BH_3 and B_3H_7 as

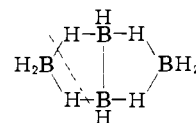

This process has been called "symmetrical cleavage" by analogy with a similar cleavage of diborane into two BH_3 groups.

Since the structure of B_4H_{10} is accurately known,⁷ an accurate determination of the structure of $\text{H}_3\text{-NB}_3\text{H}_7$, including the possible identification of

(1) Presented, in part, at the Fourth International Congress of the International Union of Crystallography, Montreal, July, 1957, and, in part, at the 133rd Meeting of the American Chemical Society, San Francisco, April, 1958.

(2) Corning Fellow, 1957-1958.

(3) G. Kodama, Doctoral Dissertation, University of Michigan, 1957.

(4) W. V. Hough, L. J. Edwards and A. D. McElroy, *THIS JOURNAL*, **78**, 689 (1956).

(5) G. Kodama and R. W. Parry, Abstracts, XVI International Congress of Pure and Applied Chemistry, Paris, 1957.

(6) L. J. Edwards, W. V. Hough and M. D. Ford, ref. 5.

(7) M. E. Jones, K. Hedberg and V. Schomaker, *THIS JOURNAL*, **75**, 4116 (1953); C. E. Nordman and W. N. Lipscomb, *ibid.*, **75**, 4116 (1953); *J. Chem. Phys.*, **21**, 1856 (1953); E. B. Moore, R. E. Dickerson and W. N. Lipscomb, *ibid.*, **27**, 209 (1957).

B_3H_7 as a fragment of B_4H_{10} , would be a significant contribution to our understanding of the chemistry of these compounds.

High Temperature Form Experimental

Samples of pure $H_2NB_3H_7$ were kindly furnished by Dr. Kodama. The compound is a crystalline solid at room temperature, stable enough to allow recrystallization from a number of common solvents such as acetone, alcohol and ether.

Powder and single crystal diffraction patterns showed the crystals to be tetragonal with $a = 6.11 \text{ \AA}$. and $c = 6.57 \text{ \AA}$., giving a calculated density of $0.765 \text{ g. cm.}^{-3}$, assuming two formula units per cell. Systematic absences observed for $h + k + l$ odd call for a body-centered lattice. These facts require each molecule in the crystal to have fourfold symmetry. This is unreasonable in view of the chemical composition of the molecule. We were therefore led to conclude that the structure is a disordered one with the molecules either axially rotating or having random orientation so as to conform to the fourfold symmetry in a statistical sense.

Diffraction intensities were recorded and visually estimated using powder, Weissenberg and precession techniques. Due to the rapid falloff of the intensities with increasing angle of diffraction, no more than 25 different intensities (hkl) could be measured.

The presence of disorder led us to investigate the possible existence of a phase transition at lower temperature. A transition was indeed found, but the equilibrium temperature of the transition could not be accurately determined due to considerable supercooling. It was however established that the transition point is no lower than -16° . Single crystals cooled through the phase transition shattered completely.

Structure Determination.—Since disorder about the c -axis direction was known to exist, the space groups having a complete set of mirror planes parallel to that direction appeared to be the most likely choices. These are C_{4v}^2 -I4mm and D_{4h}^{17} -I4/mmm. The latter of the two requires an additional disorder with the molecules pointing up or down the c -axis at random, barring the chemically very unlikely possibility that the molecules possess a mirror plane perpendicular to their axis of disorder. The high dipole moment of 6.5 Debye units found for ammonia-triborane⁸ speaks in favor of the polar space group I4mm, which permits an energetically favorable arrangement of dipoles pointing in the direction of the c -axis. This kind of arrangement has been found previously in structures composed of sterically simple or axially disordered molecules with high dipole moments such as hydrogen cyanide⁹ and ammonia-borane.¹⁰

The structure was determined by trial and error. Since only 25 independent intensities had been observed, it was essential to keep the number of parameters describing the assumed models as low as possible. The axially disordered molecules were therefore assumed to have cylindrical symmetry about the c -axis. The structure factors then are given by

$$F(hkl) = 2 \sum_{j=1}^{N/2} f_j J_0(2\pi r_j \sqrt{h^2 + k^2}) (\cos 2\pi l z_j + i \sin 2\pi l z_j)$$

where j ranges over the atoms in one molecule. r_j is the radius and z_j the z -coordinate of the "doughnut" formed by the j th atom.

(8) J. R. Weaver, G. Kodama and R. W. Parry, to be published.

(9) W. J. Dulmage and W. N. Lipscomb, *Acta Cryst.*, **4**, 330 (1951).

(10) E. W. Hughes, *This Journal*, **78**, 502 (1956); E. L. Lippert and W. N. Lipscomb, *ibid.*, **78**, 503 (1956).

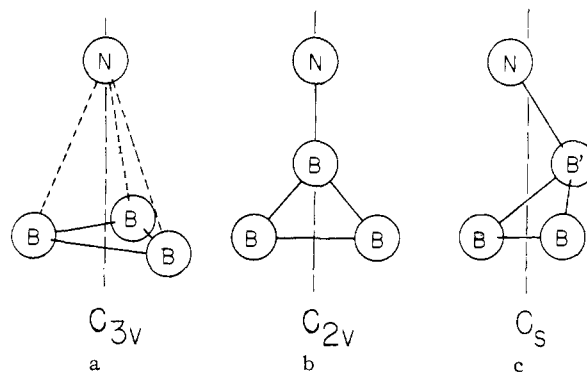

Fig. 1.—Trial models of the ammonia-triborane molecule. The z direction is vertical.

The model shown in Fig. 1a was first tried. This model has two adjustable parameters, z_N and r_B ; the origin is taken as the center of the boron ring. These two parameters, the temperature factor parameter B and the scale factor were refined by several least squares cycles yielding a final value of $R = \sum ||F_0| - |F_c|| / \sum |F_0|$ of 0.16. A $\rho(x0z)$ Fourier section computed at this stage revealed an appreciable electron density in the region between the boron ring and the nitrogen atom. This fact and the abnormally long B-N distance in the least squares result led us to try the three parameter model in Fig. 1b. Several cycles of least squares refinement now produced an R value of 0.18. A $\rho(x0z)$ electron density section and the corresponding difference synthesis now showed the distribution of the central boron atom B' to be distinctly disk shaped, requiring a non-zero $r_{B'}$. To a lesser degree the same was found to be true of the nitrogen atom. The two additional parameters $r_{B'}$ and r_N therefore were introduced (Fig. 1c) and a series of least squares refinements of all seven parameters (including B and the scale factor K) was carried out. The agreement now improved considerably, giving an R value of 0.096. An approximate hydrogen contribution with a strong additional temperature factor was now calculated assuming a reasonable distribution of the hydrogen atoms about the nitrogen and boron atoms. Following a final, slight refinement of the seven aforementioned parameters the final R factor was 0.074.

The $\rho(x0z)$ electron density section calculated at this point is shown in Fig. 2. The corresponding $(F_o - F_c)$ synthesis showed no significant region of disagreement. The observed and final calculated structure factor magnitudes are listed in Table I.

In order to examine the validity of the assumption that the disordered molecules have cylindrical symmetry the $\rho(xy0)$ and $\rho(xy z_B)$ sections were computed. Neither one revealed any noticeable departure from cylindrically distributed molecules. This may be due to strong angular motion of the molecules or to poor resolution afforded by the available data, or both. The X-ray data do not warrant any detailed conclusion regarding the angular distribution or the amount of rotational freedom of the disordered molecules.

The final least squares parameters are $r_B = 0.151$, $r_{B'} = 0.159$, $z_{B'} = 0.190$, $r_N = 0.040$ and

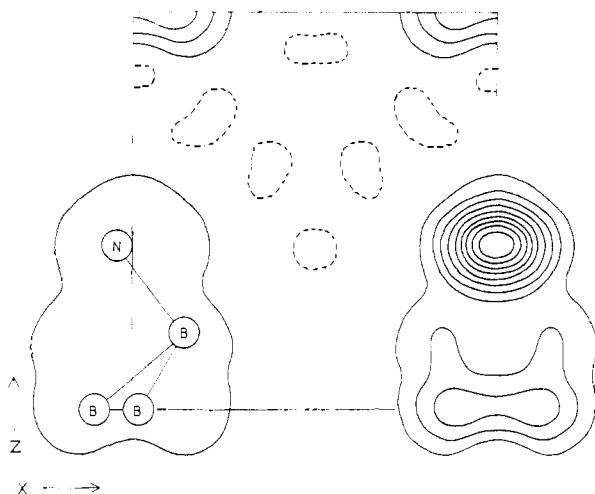

Fig. 2.—Electron density distribution at $y = 0$ in the unit cell of the disordered, high temperature structure. Contours are at intervals of 0.4 e. \AA.^{-3} ; zero contour broken.

$z_N = 0.408$. The parameter B in the temperature factor $\exp(-B \sin^2\theta/\lambda^2)$ is 8.4 \AA.^2 . The configuration of the molecule, shown in Fig. 1c, can be described as a triangle of boron atoms with an out of plane NH_3 group attached to one corner. No bond distances can be deduced unambiguously, but certain limits can be placed on them. The diameter $2r_B$ of the two atom boron ring is 1.85 \AA. ;

TABLE I
OBSERVED AND CALCULATED STRUCTURE
AMPLITUDES (HIGH FORM)

hkl	$ F_o $	$ F_c $	hkl	$ F_o $	$ F_c $	hkl	$ F_o $	$ F_c $
000	..	64.0	211	6.3	5.6	323	1.4	1.5
002	14.9	15.9	213	3.1	3.1	330	<0.8	0.0
004	4.1	4.4	215	1.3	1.2	332	<1.9	1.3
101	13.1	14.2	220	3.1	3.1	400	<0.9	0.1
103	6.2	5.7	222	3.2	3.3	402	<1.8	1.5
105	3.7	3.5	224	<1.3	1.3	411	2.2	2.4
110	25.5	25.6	301	4.5	4.2	413	<1.6	1.0
112	9.4	8.4	303	1.9	2.0	420	<1.2	0.0
114	2.7	2.6	310	1.3	1.7	422	<1.9	1.0
200	12.6	11.5	312	2.0	2.7	431	<1.2	1.1
202	6.1	5.6	314	1.3	1.3	501	1.5	1.1
204	2.0	1.7	321	2.7	3.3	510	<1.3	0.2

this is the maximum value of the B-B distance. The B-B' distances are approximately 1.8 \AA. , assuming that they are equal and that B-B equals $2r_B$. The B'-N distance must be in the range $1.7 \pm 0.2 \text{ \AA.}$ These bond lengths agree satisfactorily with values previously found in molecules containing comparable bonds.

Low Temperature Form

Experimental

In order to prepare crystals of the low temperature form, a diethyl ether solution of the compound was evaporated while maintained under a slow stream of dry nitrogen in a vial immersed in a chlorobenzene slush bath at -45° . In this way satisfactory crystals could be obtained in a few hours. The crystals were mounted and sealed in thin walled glass capillaries on a simple microscope cold stage. While on the X-ray camera the specimen was maintained at $-80 \pm 10^\circ$ by means of a stream of cold nitrogen gas.

The crystals are monoclinic and belong to the space group $P2_1/n$. The lattice parameters and their estimated standard deviations are

$$\begin{aligned} a &= 10.40 \pm 0.015 \text{ \AA.} \\ b &= 4.824 \pm 0.006 \text{ \AA.} \\ c &= 9.997 \pm 0.012 \text{ \AA.} \\ \beta &= 115.2 \pm 0.15^\circ \end{aligned}$$

These values were derived from measurements of high angle reflections on a number of precession patterns of zero level principal and diagonal nets. With four molecules of $\text{H}_3\text{-NB}_2\text{H}_7$ per unit cell the calculated density is $0.827 \text{ g. cm.}^{-3}$, an increase of 8% over the density of the high temperature form. No molecular symmetry is demanded.

Data were collected as zero and upper level patterns on the Buerger precession camera using $\text{Mo K}\alpha$ radiation. Reciprocal space was covered systematically to $\sin \theta/\lambda = 0.572$, corresponding to a zero level precession angle of 24° . Within this range 69% of the diffraction maxima were of measurable magnitude, 25% were unobservably weak and 6% were not evaluated. Including 29 spots observed outside the range a total of 502 reflections were observed. Intensities were measured visually by comparison with a scale of timed exposures and reduced to structure amplitudes in the usual way. The calculation of the Lorentz-polarization factor¹¹ and all subsequent least squares refinements and Fourier syntheses were performed on an IBM 650 computer.

Structure Determination.—With the knowledge of the structure of the boron-nitrogen skeleton gained from the high temperature form approximate boron and nitrogen coordinates easily were found. The $h0l$ Patterson projection was readily interpreted; x - and z -coordinates for the boron and nitrogen atoms were obtained from the corresponding Fourier projection. Approximate y -coordinates were found by trial and error.

A three-dimensional least squares refinement of these coordinates and the scale and temperature factors, K and B , was then carried out. The quantity $R' = \Sigma w(KF_o - F_c)^2 / \Sigma wK^2F_o^2$ was minimized, taking $w(hkl)$ as $3|F_{\text{min}}/F_o(hkl)|$ or unity, whichever was smaller. McWeeny¹² atomic scattering factors were employed; in the case of boron the "average" scattering factor f' was used. Toward the end of the refinement a contribution was included for six half-hydrogens forming a ring about the nitrogen atom. This was done to account in an approximate way for the three ammonia hydrogen atoms, whose approximate locations could be inferred. No other assumptions were made regarding hydrogen atoms. An R factor of 0.19 was reached.

The seven hydrogen atoms on the boron skeleton were now located by means of three-dimensional $(KF_o - F_{N,B})$ difference Fourier syntheses. This was done in two steps; only the strongest of the presumptive hydrogen peaks in the first difference synthesis were included in an intermediate model, which then was subjected to further refinement of N and B coordinates. A second $(KF_o - F_{N,B})$ synthesis yielded the rest of the hydrogens. This procedure was probably unnecessarily conservative, since in essence all peaks found in the first difference Fourier were ultimately confirmed as hydrogen atoms.

Anisotropy was observed in the thermal motion of the nitrogen and, to a small extent, boron atoms. This was accounted for in an approximate way by

(11) J. Waser, *Rev. Sci. Instr.*, **22**, 563 (1951); R. D. Burbank, *ibid.*, **23**, 321 (1952).

(12) R. McWeeny, *Acta Cryst.*, **4**, 513 (1951).

TABLE II
OBSERVED STRUCTURE FACTORS ($\times 10$). LOW FORM^a

00(2-10): 29, a, 124, a, w, a, 60, a, 28; 01(1-11): 248, 4, 213, 87, 16, 115, 58, 24, 17, 11, 26; 02(0-9): 53, 129, 65, 70, 124, 32, w, 55, 46, 32; 03(2-8): 38, 35, 38, 86, w, w, 28; 04(1-7): 31, w, 61, 27, 23, w, 17; 05(2-4): 24, w, 20; 10(II-9): 58, a, w, a, w, a, 96, a, 26, a, u, a, 201, a, 281, a, 72, a, 116, a, 43; 11(II-10): 28, 38, w, w, 20, 58, 108, 9, 69, 158, 201, 306, 273, 65, 100, 141, 57, w, 23, 58, 32, 34; 12(10-7): 16, 41, 34, 58, 97, 40, 44, 22, 106, 30, 103, 87, 95, 34, 125, 75, 43, 40; 13(7-8): 58, 61, w, 70, 100, 30, 67, 48, 105, w, 19, 33, 43, w, w, 33; 14(4-6): 58, w, 49, w, u, w, w, w, w, w, 44; 15(4-1): 18, 50, 30, 40, 38, 38; 20(10-10): 68, a, 14, a, 33, a, 228, a, 401, a, 62, a, 191, a, 62, a, 107, a, w, a, 39; 21(II-9): 39, 60, w, w, 76, 12, 68, 24, 236, 78, 164, 143, 212, 56, 7, 174, 93, w, 34, 22, 17; 22(10-8): 35, 41, w, w, 123, 58, w, 47, 92, 42, 109, 121, 117, 49, 41, 100, w, w, 26; 23(9-6): 38, w, 61, 41, w, 33, 30, w, 32, 92, 117, 22, 31, 49, 33, 34; 24(7-1): 32, w, 78, w, 32, w, 52, w, 44; 25(0-3): 55, 31, w, 25; 30(II-9): 50, a, 66, a, 67, a, 89, a, 173, a, 223, a, 163, a, 31, a, 135, a, w, a, 72; 31(9-8): 38, 28, 81, 17, 55, 56, 66, 168, 109, 124, 99, 114, 46, 39, 76, 76, w, 43; 32(10-8): 73, w, 22, 38, 65, w, w, 89, 63, 87, 115, 161, 30, 51, 42, 55, w, w, 29; 33(9-6): 45, 27, w, 111, 89, 35, u, w, 56, w, 17, 30, w, 55, w, 25; 34(6-2): 51, w, 39, w, 102, w, 60, w, 38; 35(3): 28; 40(12-8): 51, a, 16, a, 33, a, 138, a, 37, a, 116, a, 35, a, 18, a, 78, a, 48, a, 49; 41(12-5): 41, u, 25, 74, w, w, 84, 157, 14, 19, 62, 127, 204, 24, 82, 52, 22, 52; 42(8-4): 57, 66, 22, w, 89, 19, 37, 59, 68, 113, 27, 92, 81; 43(6-4): 36, u, w, 19, 95, 141, w, 46, 76, w, 28; 44(7-1): 34, w, 59, w, 41, w, 50; 45(2-1): 50, 34; 50(II-7): 29, a, 52, a, 71, a, 189, a, 74, a, 93, a, 59, a, 99, a, 53, a, 51; 51(II-6): 54, w, u, w, 32, 86, 38, 83, 16, 120, 89, 34, 55, 104, 72, 53, 17, 37; 52(8-5): 56, 26, 61, 44, 64, w, 63, 169, w, w, 32, 70, 24, 32; 53(8-5): 32, 36, 25, 30, w, 22, w, w, 63, 24, 39, w, 43, 49; 54(8-0): 21, w, 55, w, 29, w, 59, 29, 53; 60(12-6): 18, a, 54, a, 72, a, w, a, 58, a, 104, a, 89, a, 48, a, 59, a, 67; 61(II-6): 29, 15, u, 56, 86, 66, 25, 45, 25, 74, 47, 26, 19, 25, 45, 32, 32, 12; 62(9-5): 27, 28, u, w, 31, 30, 33, 30, 120, 32, w, 47, w, u, 17; 63(8-3): 23, 33, 40, 37, 50, 55, w, 44, 59, w, 22, 31; 64(5-1): 55, w, 32, w, w, w, 24; 70(7-5): 121, a, w, a, 81, a, 27, 0, 71, a, 68, a, 15; 71(II-0): 17, u, w, 59, 11, 29, 22, 95, 44, 10, 97, 116; 72(6-2): 62, 46, w, 64, w, 37, 54, 38, 33; 73(7-3): 30, 27, 28, u, w, 57, 25, w, w, 26, 36; 74(6-4): 39, a, 74, a, 82, a, 98, a, 12, a, 81; 81(II-5): 21, 10, u, 29, 27, 47, w, 11, 26, 46, 11, 27, 34, 24, 56, 33, 17; 82(8-1): 35, w, 53, 34, 40, 79, 27, 38, u, 29; 83(8-0): 29, 35, 25, w, 32, w, w, 48, 35; 84(5): 15; 90(9-3): 36, a, 23, a, 21, a, w, a, 53, a, 31, a, 41; 91(10-3): 41, w, 19, 42, 40, 23, 11, 53, 73, 14, 20, w, 25, 12; 92(7-1): 35, w, u, u, 43, 43, 34, w, 24; 93(7-3): 30, 66, u, u, 35; 10.0.(10-2): 34, a, 43, a, w, a, w, a, 64, a, 24, a, 57; 10.1.(7-1): 33, 29, w, 12, 30, 36, 25, w, 46; 10.2.(8-2): 22, 42, u, w, u, w, 32; 10.3.3: 40; 11.0.(9-1): 35, a, 40, a, 39, a, 20, a, w, a, 37; 11.1.(7-3): 34, u, 11, 17, 12; 11.2.3: 31; 12.0.(6-2): 21, a, 14, a, 45; 12.1.(8-3): 32, 14, w, 33, 13, 9; 13.0.(7-5): 35, a, 15.

^a a = absent due to symmetry; w = too weak to be observed; u = not evaluated.

applying two anisotropic temperature corrections, one to f_N and another to f_B , common to all boron atoms. With the hydrogen atoms and the partial anisotropy correction included least squares refinement of K , over-all B , and nitrogen and boron coordinates improved the agreement to $R = 0.117$.

A set of sections of the three-dimensional ($KF_0 - F_{N,B}$) synthesis computed at this stage are shown in Fig. 3. All spurious peaks are less than one-half the height of the lowest hydrogen peak. This does not include the region of moderately high electron density found in the neighborhood of the nitrogen atom and presumably due to the three unresolved ammonia hydrogens.

The method employed in refining the assumed model structure was now revised to allow all atoms

to assume individual, but isotropic, thermal parameters, and several cycles of least squares refinement of all coordinates and thermal parameters were carried out. The shifts in coordinates were slight and led to final values of $R = 0.107$ and $R' = 0.019$.

An attempt was now made to find the locations of the three ammonia hydrogens, which had not been found as resolved peaks in any of the difference syntheses. Vaguely suggested maxima in the neighborhood of the nitrogen atom were taken as a starting point for a series of least squares refinements of all parameters except those relating to the seven hydrogens already found. This refinement failed to improve the agreement previously obtained; in seven cycles the values $R = 0.113$

TABLE III
 ATOMIC PARAMETERS AND THEIR STANDARD DEVIATIONS

Atom	<i>x</i>	<i>y</i>	<i>z</i>	<i>B</i>
N	0.2007 ± 0.00012	0.4383 ± 0.0003	0.4799 ± 0.00013	2.91 ± 0.13
B ₁	-.0641 ± .0005	.5437 ± .0009	.2441 ± .0004	3.18 ± .09
B ₂	.0629 ± .0003	.6860 ± .0010	.1935 ± .0004	3.14 ± .14
B ₃	.1000 ± .0002	.6805 ± .0005	.3868 ± .0003	2.62 ± .08
H ₁	-.153 ± .006	.678 ± .010	.232 ± .005	2.8 ± 1.1
H ₂	-.067 ± .004	.313 ± .006	.283 ± .003	3.0 ± 0.7
H ₃	-.063 ± .007	.538 ± .008	.122 ± .003	2.3 ± 1.4
H ₄	.042 ± .009	.893 ± .016	.138 ± .007	4.4 ± 0.8
H ₅	.148 ± .003	.549 ± .011	.190 ± .005	1.8 ± .8
H ₆	.169 ± .005	.834 ± .007	.365 ± .004	2.0 ± .7
H ₇	.052 ± .005	.802 ± .011	.452 ± .004	1.6 ± .7

and $R' = 0.021$ were reached. Perhaps more significantly, the thermal parameters of the three ammonia hydrogens refined to very high values, 5.3, 11.1 and 11.8, suggesting a high degree of rotational freedom. Since, in addition, the H-N and H-H distances in the NH₃ group refined to unconvincing values, we conclude that the three hydrogens cannot be located unambiguously, presumably due to strong angular motion about the B-N bond.

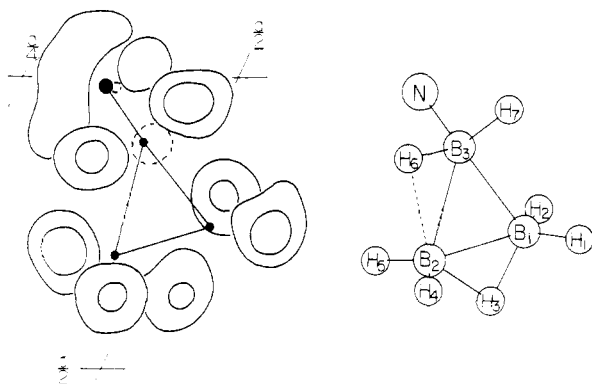

Fig. 3.—Left, the electron density distribution in the H₃NB₃H₇ molecule represented by sections near the centers of the hydrogen atoms. The nitrogen and boron atoms have been subtracted out and are indicated schematically. Contours are at -0.25 (broken), +0.25 and +0.50 e. Å.⁻³. Right, schematic drawing of the same molecule and key to the numbering of atoms.

The observed and final calculated structure factors are given in Table II. The values and standard deviations of the atomic coordinates and the thermal parameters are listed in Table III. The standard deviations were deduced in the following way. The observed structure factors were divided into six equal sets with the same distribution in $\sin \theta/\lambda$ but otherwise selected at random. Starting with the parameters given in Table III each set was separately subjected to least squares refinement. Usually the refinement was virtually completed in four or five cycles. The resulting six sets of coordinates and thermal parameters constitute, in effect, six independent structure determinations. The standard deviations of the final parameters can be taken as the standard deviations of the means of these quantities as given by $(\sum r_i^2)^{1/2}/[n(n-1)]^{1/2}$, where the r_i 's are the deviations from the means of the individual

values, and $n = 6$ in this case. The difference between the mean of a parameter as obtained from the six sets and the final (Table III) value was in all cases less than the standard deviation.

Discussion

Interatomic distances and bond angles in the ammonia-triborane structure are given in Table IV. The standard deviations were obtained from an analysis of the interatomic distances calculated from the six separate sets of coordinates. They include contributions from the standard deviations in the cell parameters, which in the case of the B-N and B-B distances are comparable to those resulting from the standard deviations in the coordinates. It is clear that standard deviations estimated in this manner fail to reflect any systematic errors in the bond lengths conceivably introduced by incorrectly assumed scattering factor curves.¹³

 TABLE IV
 INTERATOMIC DISTANCES AND BOND ANGLES

A. Bond lengths, Å.		B. Non-bonded intramolecular distances, Å.	
N-B ₃	1.581 ± 0.003	N...B ₁	2.806 ± 0.007
B ₁ -B ₂	1.744 ± .005	N...B ₂	2.861 ± .005
B ₁ -B ₃	1.820 ± .006	N...H ₆	2.18 ± .04
B ₂ -B ₃	1.803 ± .006	N...H ₇	2.28 ± .07
B ₁ -H ₁	1.09 ± .03	B ₁ ...H ₇	2.28 ± .04
B ₁ -H ₂	1.18 ± .04		
B ₁ -H ₆	1.23 ± .03		
B ₂ -H ₃	1.39 ± .05		
B ₂ -H ₄	1.12 ± .05		
B ₂ -H ₅	1.11 ± .04		
B ₂ -H ₆	1.75 ± .03		
B ₃ -H ₆	1.12 ± .03		
B ₃ -H ₇	1.14 ± .07		

C. Bond angles, degree			
		NB ₃ B ₁	111.0 ± 0.5
		NB ₃ B ₂	115.3 ± .5
		NB ₃ (B plane)	117.2 ± .5

D. Short intermolecular distances			
Atom of reference molecule ^a	Atom of neighbor molecule	Molecules related by	Distance, Å.
H ₇	H ₂	Center at (0, 1/2, 1/2)	2.65
H ₇	H ₇	Center at (0, 1, 1/2)	2.57
H ₆	H ₅	2 ₁ axis at $x = z = 1/4$	2.43
H ₄	H ₄	Center at (0, 1, 0)	2.72

^a Atomic coordinates of the reference molecule are given in Table III.

Topologically, the B₃H₇ group is readily identified with the fragment of tetraborane produced by symmetrical cleavage of the double bridge inferred on chemical grounds. A comparison of the

(13) F. L. Hirshfeld, K. Eriks, R. E. Dickerson, E. L. Lippert and W. N. Lipscomb, *J. Chem. Phys.*, **28**, 56 (1958).

detailed geometry with that of tetraborane¹⁴ nevertheless reveals several significant differences. The non-bridged boron-boron distance B_1-B_3 is considerably longer than the value 1.712 Å. found for its presumptive counterpart in tetraborane. This may be related to the change of the neighboring B_1-H_2 from a bridge to a regular boron-hydrogen bond. On the other hand, the bridged B_1-B_2 distance is much shorter than any of the four bridge B-B distances in tetraborane, all of which lie in the range 1.842 ± 0.007 Å. Perhaps the most striking difference is the strong asymmetry of the $B_2H_6B_3$ hydrogen bridge. While the B_3-H_6 distance is indistinguishable from a single B-H bond, the B_2-H_4 distance of 1.75 Å. is almost 0.4 Å. longer than the corresponding B-H bridge distances in B_4H_{10} or any other boron hydride. Boron-hydrogen distances approximating this value are found in B_5H_{11} ,¹⁴ but they are not part of BHB bridges of the usual kind.

The over-all effect of these distortions from the B_4H_{10} geometry may be interpreted as a tendency toward the structure of a bridge substituted diborane, $(H_3NBH_2)B_2H_5$. The nearly planar configuration of $H_1H_2B_1B_2H_4H_5$ and the closeness of the B_1-B_2 distance to the value 1.770 ± 0.013 Å. found in diborane¹⁵ would seem to support this interpretation, which presumably would require the free molecule to have a plane of symmetry perpendicular to B_1-B_2 . Since B_2-H_6 and $B_1 \dots H_7$ are clearly different, as are $N \dots B_1$ and $N \dots B_2$, a molecular symmetry plane certainly is not present in the crystal. The H_3NBH_2 group, however, has a plane of symmetry, within experimental error, as shown by its B-H and N...H distances. The violations of the molecular symmetry plane can then largely be accounted for in terms of a tilt of the H_3NBH_2 group with respect to B_2H_5 , such as to "crowd" H_6 into B_2 . Support for the hypothesis that this might be due to intermolecular repulsions could be sought in the geometry of the close intermolecular contacts involving H_6 and H_7 (Table IV). This approach is inconclusive, however, since the H_3NBH_2 group is about equally closely surrounded by neighbors on both sides.

In spite of the above considerations, we feel that the asymmetry of the molecule, which also includes the presumably significant asymmetry of the $B_1H_3B_2$ bridge, is probably too large to be accounted for by mere intermolecular packing forces. Using the formulation of Eberhardt, Crawford and Lipscomb¹⁶ our results suggest that the boron triangle in $H_3NB_3H_7$ is held together by two BHB bridge bonds and one (B_1-B_3) electron pair bond, but the alternative description in terms of one hydrogen bridge ($B_1H_3B_2$) and a central three center bond ($B_1B_2B_3$) cannot be entirely ruled out.

(14) E. B. Moore, R. E. Dickerson and W. N. Lipscomb, *J. Chem. Phys.*, **27**, 209 (1957).

(15) K. Hedberg and V. Schomaker, *THIS JOURNAL*, **73**, 1482 (1951).

(16) W. H. Eberhardt, B. Crawford and W. N. Lipscomb, *J. Chem. Phys.*, **22**, 989 (1954); R. E. Dickerson and W. N. Lipscomb, *ibid.*, **27**, 212 (1957).

The N- B_3 distance is in satisfactory agreement with other, less accurately determined N-B distances in boron hydride derivatives¹⁷; it shows particularly close agreement with the more accurately determined boron-nitrogen distances in the addition compounds of boron trifluoride with ammonia and methyl amines.¹⁸

The packing of molecules in the low temperature structure viewed down the b -axis is shown in the $h0l$ Fourier projection of Fig. 4. As in the high

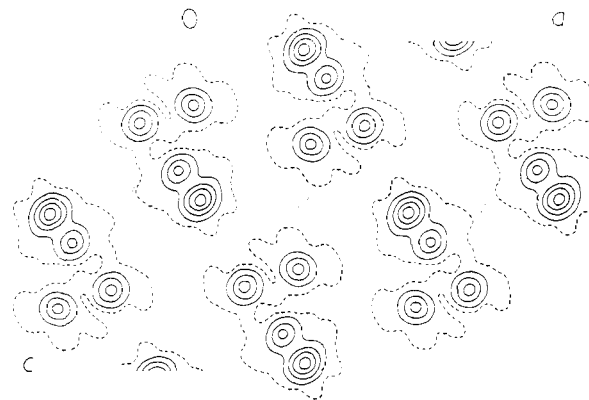

Fig. 4.—Projection onto (010) of the electron density in the low temperature structure, showing the packing of molecules. Contours are at 1 (broken), 2, 4, 6 and 8 $e \cdot \text{Å}^{-3}$.

temperature modification the end-to-end arrangement is apparent, in this case in the direction of the diagonal glide translation. Molecules in neighboring "chains" lie next to each other rather than staggered as in the high temperature form; this arrangement amounts to a favorable stacking of dipoles pointing in two opposite directions.

A low temperature heat capacity study by Westrum and Levitin,¹⁹ carried out after the completion of the experimental part of the X-ray study, has established the transition temperature as 297.10°K. As pointed out by these authors, the entropy of transition, 4.15 cal. deg.⁻¹mole⁻¹, is approximately equal to $R \ln 8$. It is interesting to note that the number of equivalent general positions in the space group $I4mm$ is 8, that is, if the only effect of the phase transition were a randomization over these positions of the angular orientation of each molecule, independent of its neighbors, the entropy change would very nearly equal the experimental value.

Acknowledgment.—This work was conducted, in part, under Contract AF 33(616)-3343 with the U. S. Air Force, the sponsoring agency being the Aeronautical Research Laboratory of the Wright Air Development Center, Air Research and Development Command.

ANN ARBOR, MICHIGAN

(17) E. W. Hughes, *THIS JOURNAL*, **78**, 502 (1956); E. L. Lippert and W. N. Lipscomb, *ibid.*, **78**, 503 (1956); C. E. Nordman and C. R. Peters, *ibid.*, **81**, 3551 (1959).

(18) J. L. Hoard, S. Geller and T. B. Owen, *Acta Cryst.*, **4**, 405 (1951).

(19) E. F. Westrum, Jr., and N. E. Levitin, *THIS JOURNAL*, **91**, 3544 (1959).